

# BLOC DESK WITH STORAGE SHELVES

**1.5 HR**

**APPROXIMATE ASSEMBLY TIME**



**2 PERSON ASSEMBLY**

**FLOOR AREA  
2.5M X 2.0M**

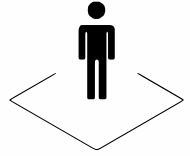

**REQUIRED ASSEMBLY SPACE**

## REQUIRED ASSEMBLY TOOLS

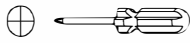

**POZI SCREWDRIVER**

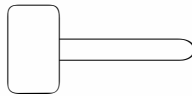

**HAMMER**

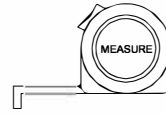

**MEASURING TAPE**

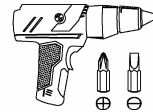

**DRILL**

## ASSEMBLED DIMENSIONS

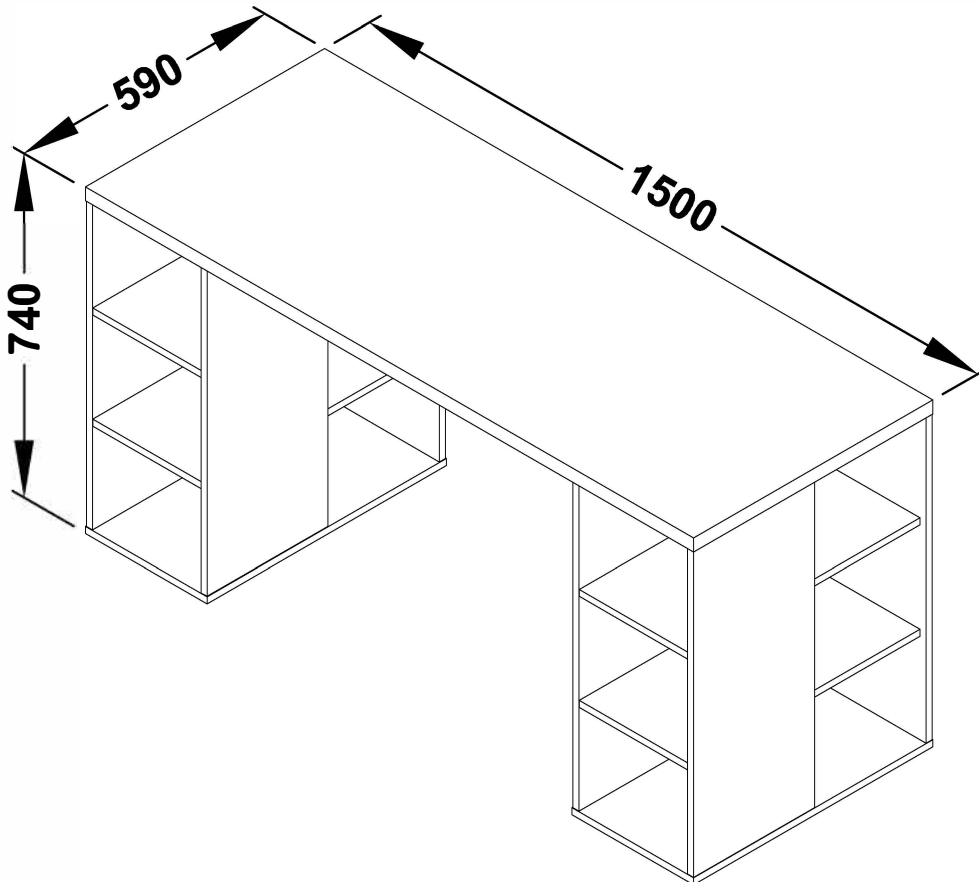

# BLOC DESK WITH STORAGE SHELVES

## Tips before you start:

1. Please check that all parts are present before you start the assembly of your furniture.
2. For ease and speed of assembly, we recommend that before you commence each step of the assembly, that you identify all the parts required for that step.
3. For larger items, please ensure that you have sufficient space and people ( as indicated on page 1 ) to assemble your product safely.
4. We recommend that, where possible, all items are assembled near to the area in which they will be placed in use, to avoid moving the product unnecessarily once assembled.
5. For the protection of your furniture, we recommend that the product is placed on a protected surface during assembly to prevent any damage.
6. During assembly please take care not to over-tighten any fittings, as this may damage the product.
7. Always place the product on a flat, steady and stable surface.
8. Do not stand on the product. Do not use the product as a stepladder.
9. This product is intended for indoor, household use only as it is non industrial product.

## Care and Maintenance of your Furniture

- Please periodically check all fittings and re-tighten as necessary.
- To clean your item, please use a damp cloth and wipe clean.
- Never allow any kind of liquid to remain on your furniture. Absorption can cause wood to warp or finishes to de-laminate.
- Please do not place hot item ( e.g. hot drinks ) directly on to the wood surface.
- Please do not drag or pull your furniture.

# BLOC DESK WITH STORAGE SHELVES

Tips before you start:

## QUICKFIT

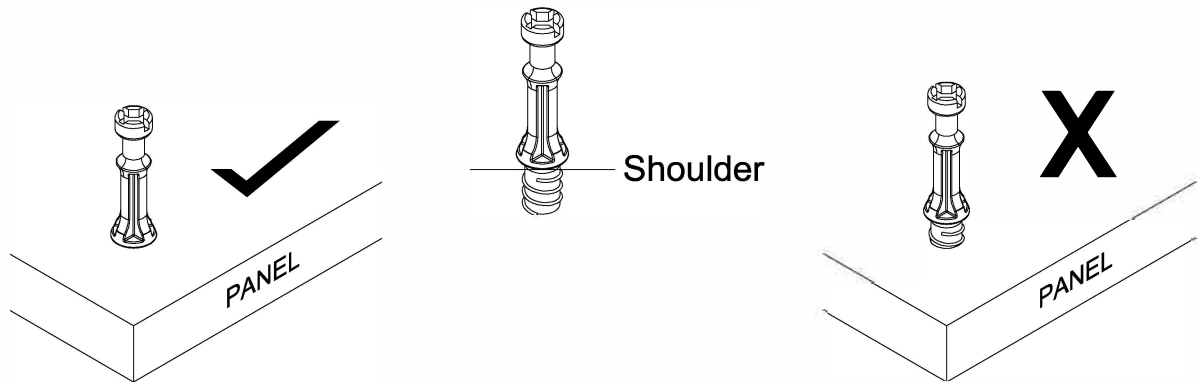

Tighten quickfit until shoulder is flush with panel. Do not overtighten or undertighten.

## CAM LOCK

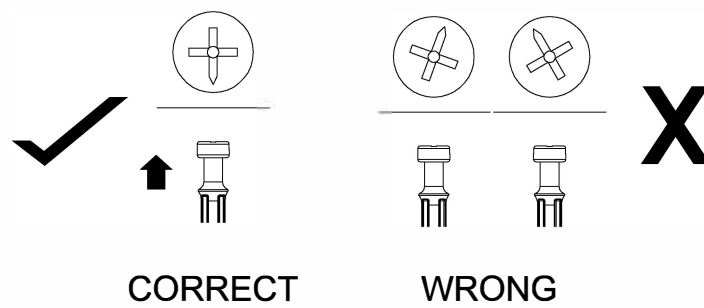

When fitting cam lock, ensure starting position is correct before you insert connecting quickfit.

Quickfit head should be in the centre of the cam lock when the two panels are joined.

Cam lock should be inserted before quickfit.

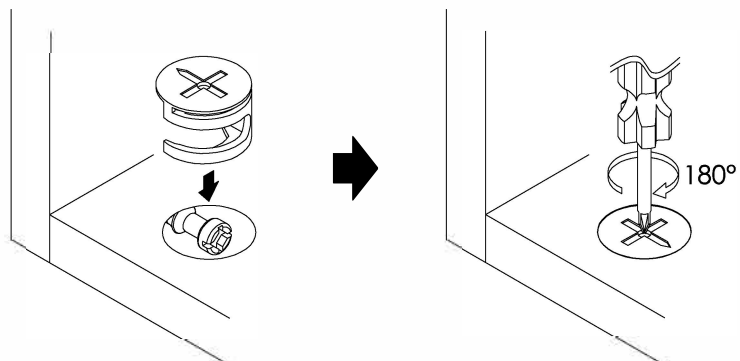

Turn camlock clockwise to tighten.

# BLOC DESK WITH STORAGE SHELVES

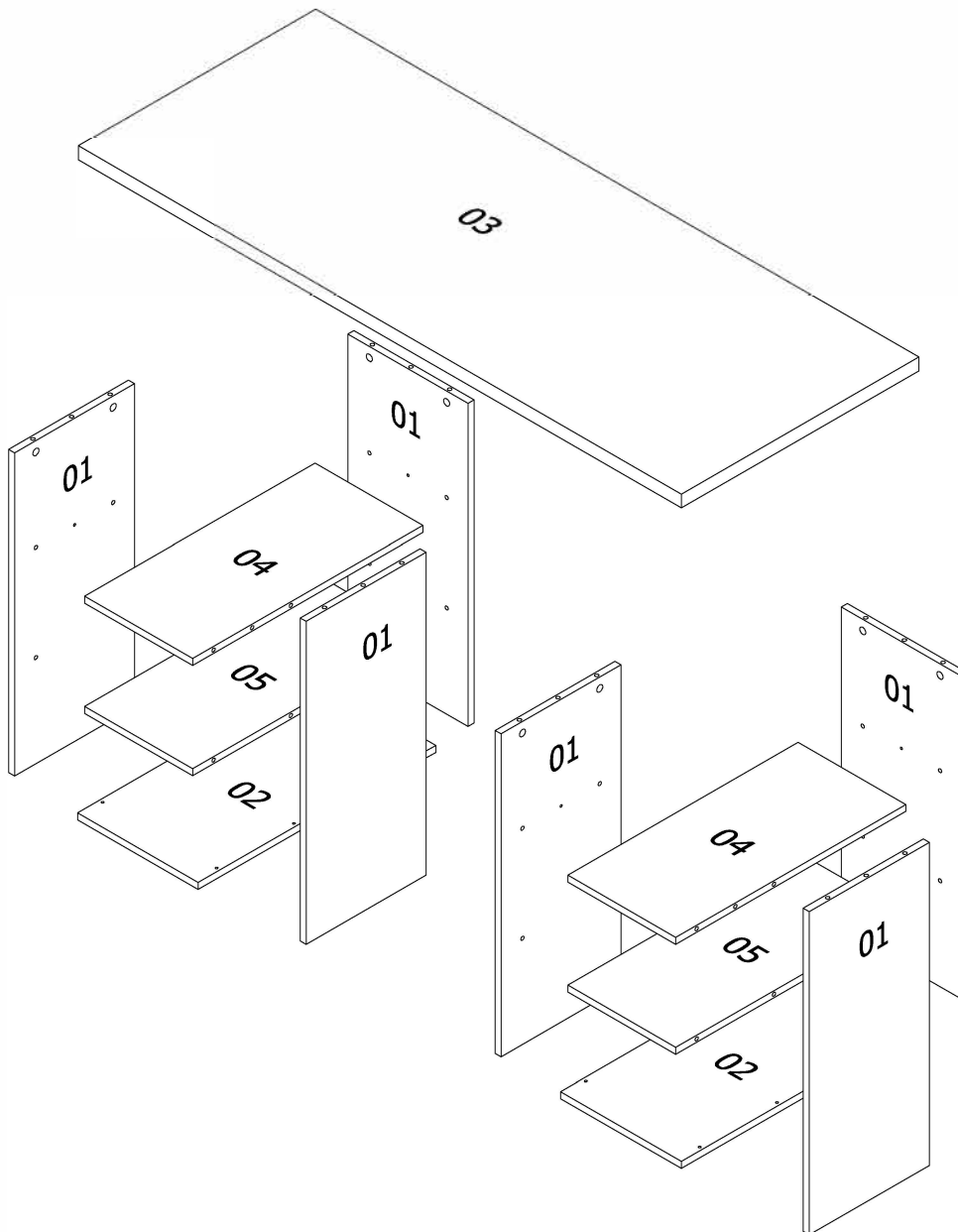





## PART LIST:

NO.	PART NAME	QTY
1	SIDE / BACK PANEL (LEFT / RIGHT)	6
2	BOTTOM PANEL	2

NO.	PART NAME	QTY
3	TOP PANEL	1
4	SHELF PANEL (TOP)	2
5	SHELF PANEL (BOTTOM)	2

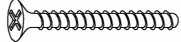
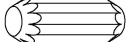
# BLOC DESK WITH STORAGE SHELVES

## HARDWARE LIST

- |  |   |   |  |
|--|---|---|--|
| <p><b>A</b> X12</p>  <p>SCREW<br/>M4.7 X 38MM</p>     | <p><b>B</b> X30</p>  <p>WOOD DOWEL<br/>Ø8 X 25MM</p> | <p><b>C</b> X18</p>  <p>BOLT-9607 PARALEL<br/>NECK DOWEL 24 X 8.5</p> | <p><b>D</b> X18</p>  <p>CAM-9642 CAM<br/>3000 12/13MM</p> |
| <p><b>E</b> X18</p>  <p>ROUND STICKER<br/>(Ø18MM)</p> | <p><b>F</b> X1</p>  <p>GLUE</p>                      |   |  |

# BLOC DESK WITH STORAGE SHELVES

## STEP 1

Using glue (F) insert dowel (B) into pieces (1, 4 & 5) as shown.

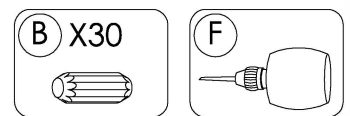
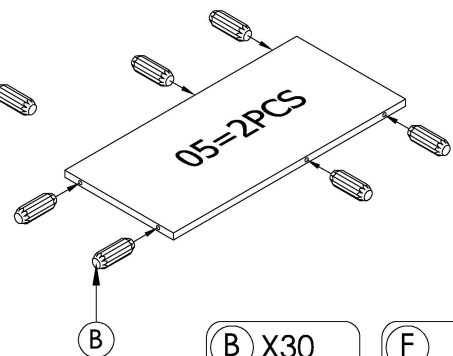
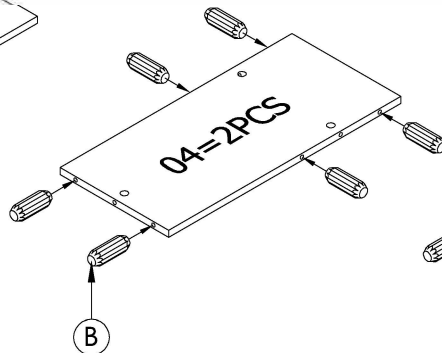
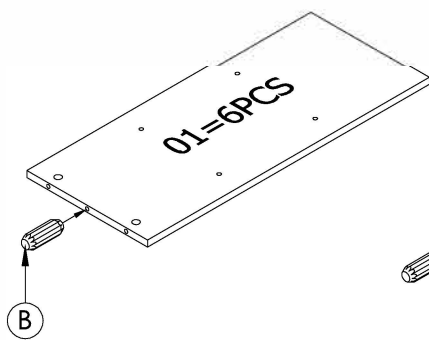
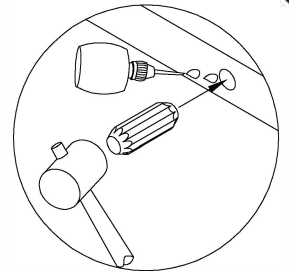

## STEP 2

Take both side panels (1 & 3), using a drill on low speed / torque or a phillips head screw driver CAM PINS (C) as shown.

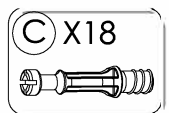
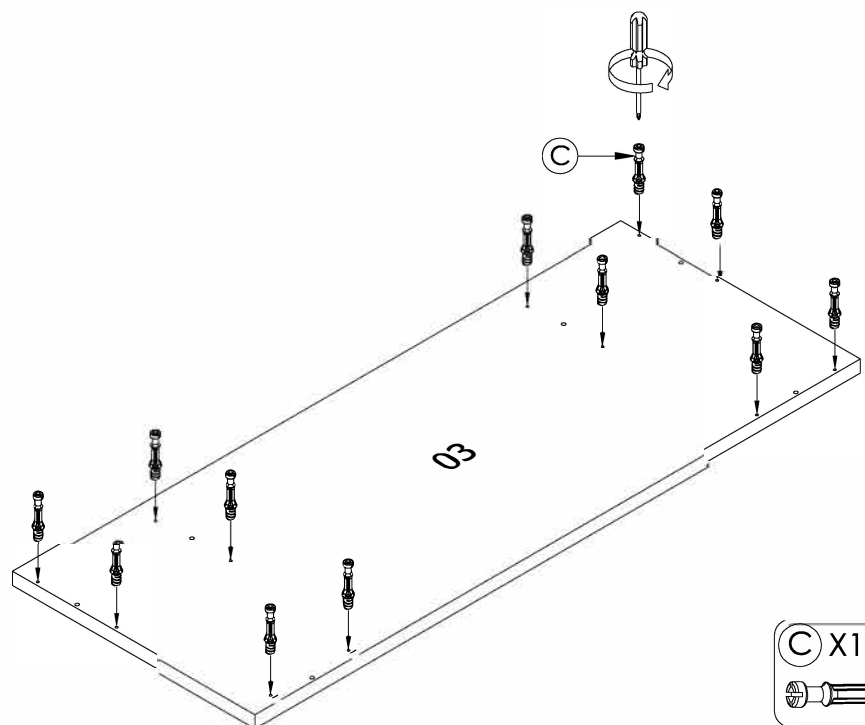
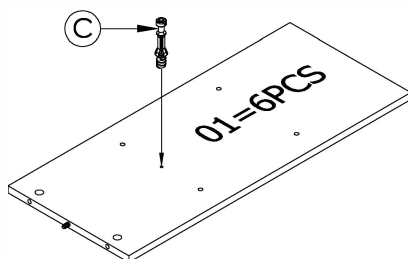

# BLOC DESK WITH STORAGE SHELVES

## STEP 3

Lay panel (1) flat (on a clean dry surface) . Using glue (F) attach with CAM LOCKS (D) panels (4). Attach 18mm round sticker(E) to top of the cam locks as shown. Attach panels (5) using glue. (NOTE: holes for feet attachment should face bottom of cabinet).

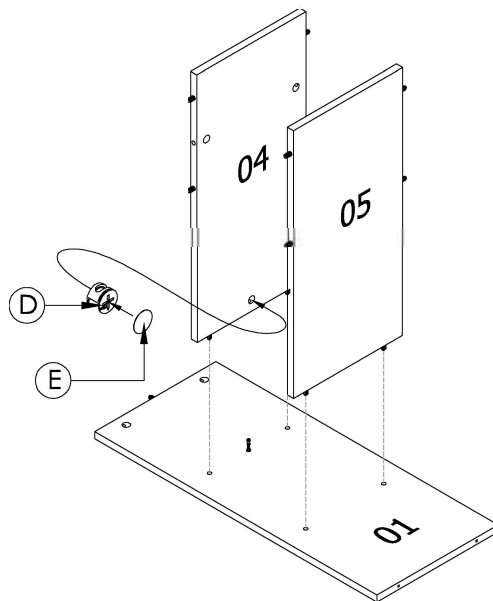
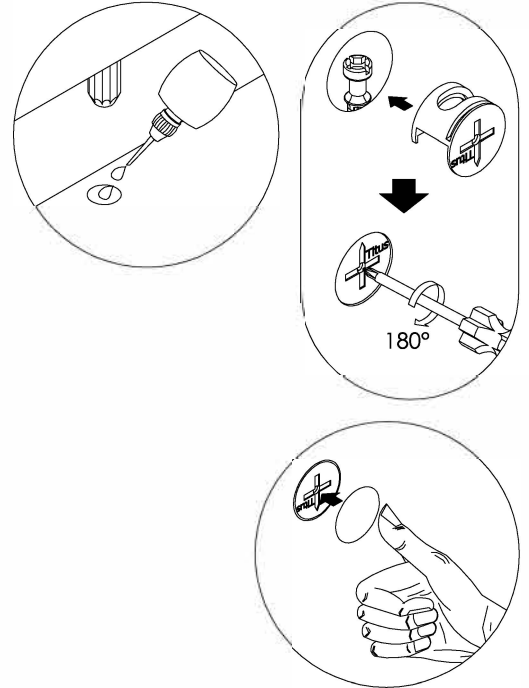

**X2**

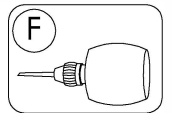
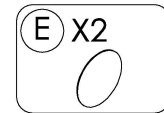
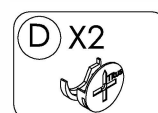

# BLOC DESK WITH STORAGE SHELVES

## STEP 4

Lay panel (1) flat (on a clean dry surface) . Using glue (F) attach with CAM LOCKS (D) panels (4). Attach 18mm round sticker(E) to top of the cam locks as shown. Attach panels (5) using glue. (NOTE: holes for feet attachment should face bottom of cabinet).

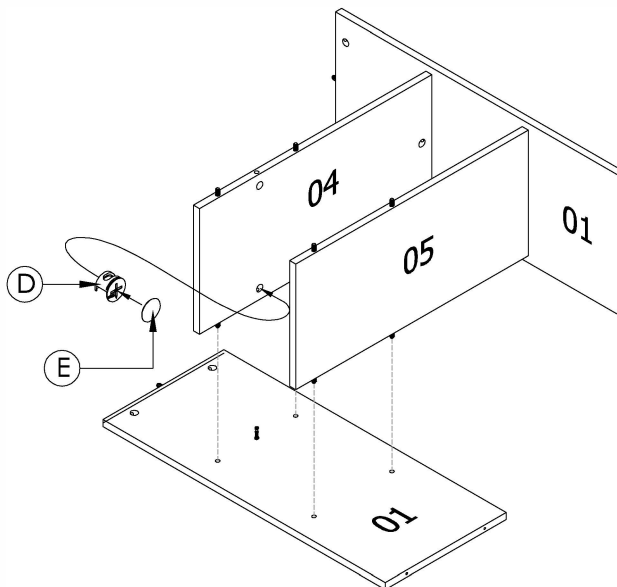
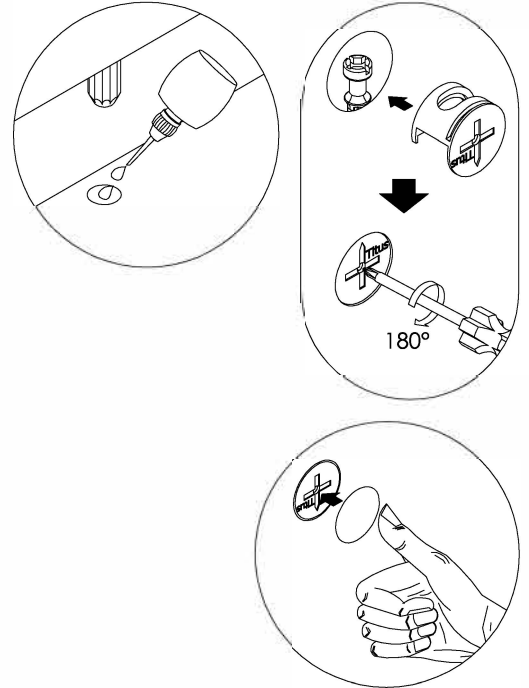

**X2**

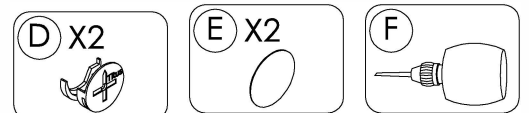



# BLOC DESK WITH STORAGE SHELVES

## STEP 5

Lay panel (1) flat (on a clean dry surface) . Using glue (F) attach with CAM LOCKS (D) panels (4). Attach 18mm round sticker(E) to top of the cam locks as shown. Attach panels (5) using glue. (NOTE: holes for feet attachment should face bottom of cabinet).

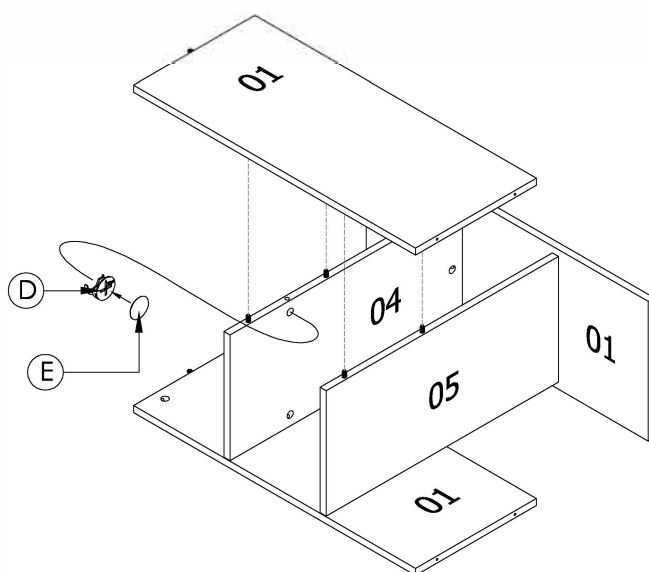
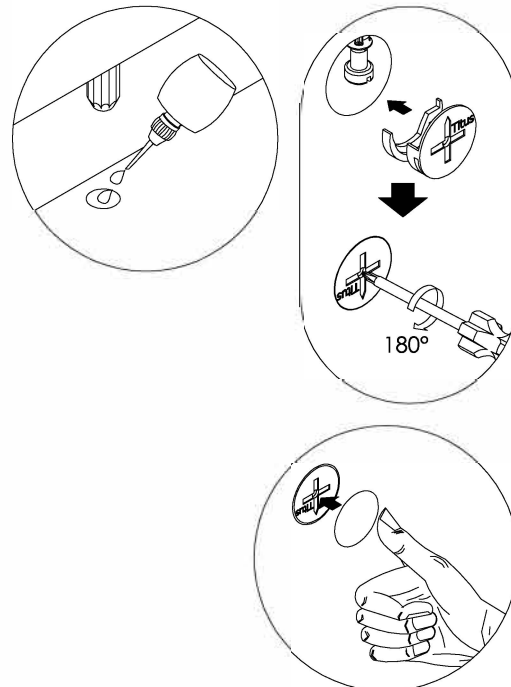

**X2**

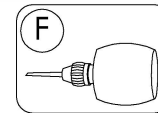
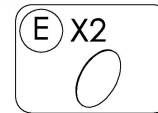
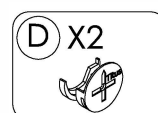

# BLOC DESK WITH STORAGE SHELVES

## STEP 6

Attach panel (2) to frame using screw (A) as shown.

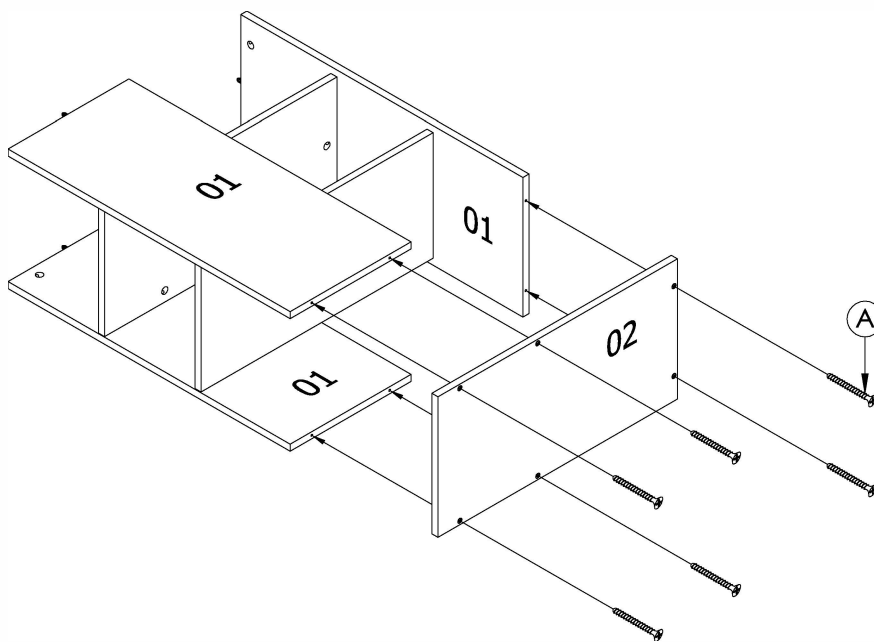

**X2**

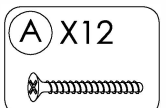

# BLOC DESK WITH STORAGE SHELVES

## STEP 7

Attach top panels (3) to frame using glue (F) and CAM LOCKS (D). Attach 18mm round sticker (E) to top of the cam locks as shown.

